

Retrofitting the support brace for Aduro 22-3

Difficulty level: Intermediate

Time consumption: 20 minutes

Tools: Bit set, Bit screwdriver

Components: Retrofit-kit (Washers, screws, 30x30x320 U-Profile)

To stiffen and make the Aduro 22-3 stove more rigid, a brace will be retrofit to it for models made before February 2023. A brace consists of the following parts:

Two braces will be needed for each stove, which is why they come in pairs.

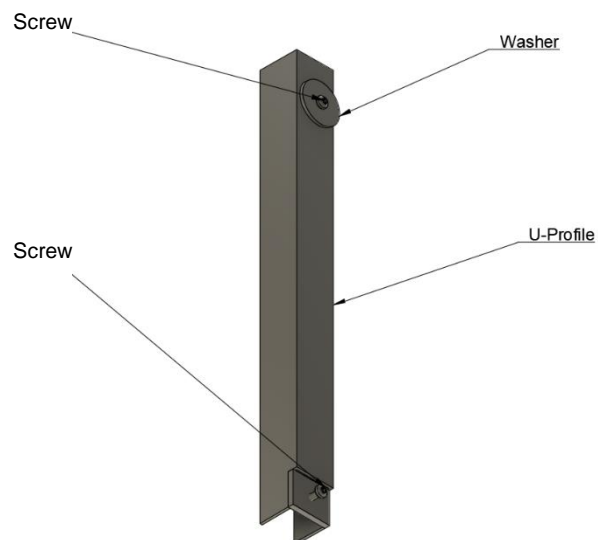

The brace will be fitted using some of the existing holes in the bottom plate of the stove:

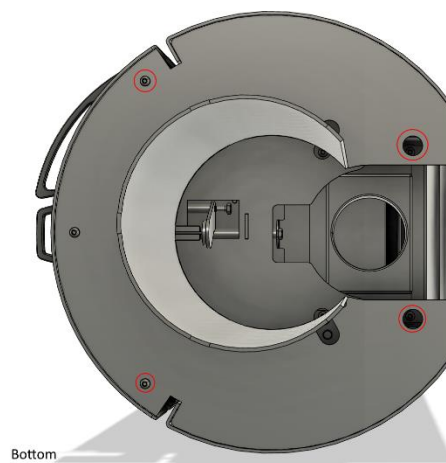

The brace will be installed, using the following steps:

Step 1. Remove front plate. The front plate can be removed by unscrewing the screws on the front part of the bottom plate:



Step 2. Place a brace in both sides with the raised part of the profile facing towards the front:



Step 3. Align the hole in the back of the U-Profile with the large hole in the back of the bottom plate, then screw in the screw with a washer on:



Step 4. Align the hole of the raised part of the U-Profile with the corresponding hole in the bottom plate. Then place the outer ears of the front plate underneath each of the U-Profiles raised bits. Insert the screw and screw the parts together:

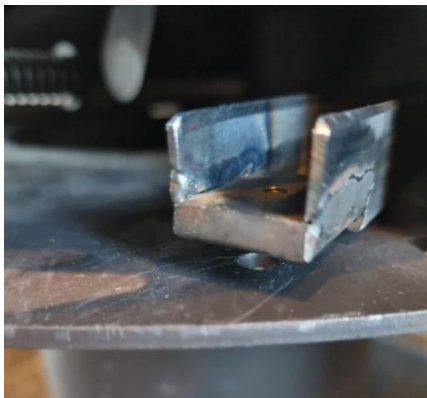

Step 5. Screw in the last screw in the middle ear of the front plate. Use the original screw for this hole.